



US 20150179724A1

(19) **United States**

(12) **Patent Application Publication**

Lee et al.

(10) **Pub. No.: US 2015/0179724 A1**

(43) **Pub. Date: Jun. 25, 2015**

(54) **ORGANIC LIGHT EMITTING DIODE DISPLAY DEVICE AND METHOD OF FABRICATING THE SAME**

(71) Applicant: **LG Display Co., Ltd.**, Seoul (KR)

(72) Inventors: **Young-Jang Lee**, Seoul (KR);
Ho-Young Jeong, Goyang-si (KR)

(21) Appl. No.: **14/575,321**

(22) Filed: **Dec. 18, 2014**

(30) **Foreign Application Priority Data**

Dec. 23, 2013 (KR) 10-2013-0161519

Publication Classification

(51) **Int. Cl.**
H01L 27/32 (2006.01)
H01L 27/12 (2006.01)
H01L 51/56 (2006.01)
H01L 29/786 (2006.01)

(52) **U.S. Cl.**
CPC **H01L 27/3272** (2013.01); **H01L 27/3262** (2013.01); **H01L 27/3265** (2013.01); **H01L 27/3258** (2013.01); **H01L 29/7869** (2013.01); **H01L 27/1259** (2013.01); **H01L 51/56** (2013.01); **H01L 2227/323** (2013.01)

(57) **ABSTRACT**

An organic light emitting diode display device comprises a driving thin film transistor including a first semiconductor layer, a gate insulating layer formed on the first semiconductor layer. The device further includes a storage capacitor including a first capacitor electrode electrically coupled to a drain electrode of the driving thin film transistor, a buffer layer formed on the first capacitor electrode, a second semiconductor layer formed on the buffer layer, and a second capacitor electrode formed on the second semiconductor layer and electrically coupled to a gate electrode of the driving thin film transistor. The device also includes an organic light emitting diode connected to the drain electrode of the driving transistor. The gate insulating layer has at least one hole in a region where the gate insulating layer overlaps the second semiconductor layer, thereby exposing the second semiconductor layer to the second capacitor electrode.

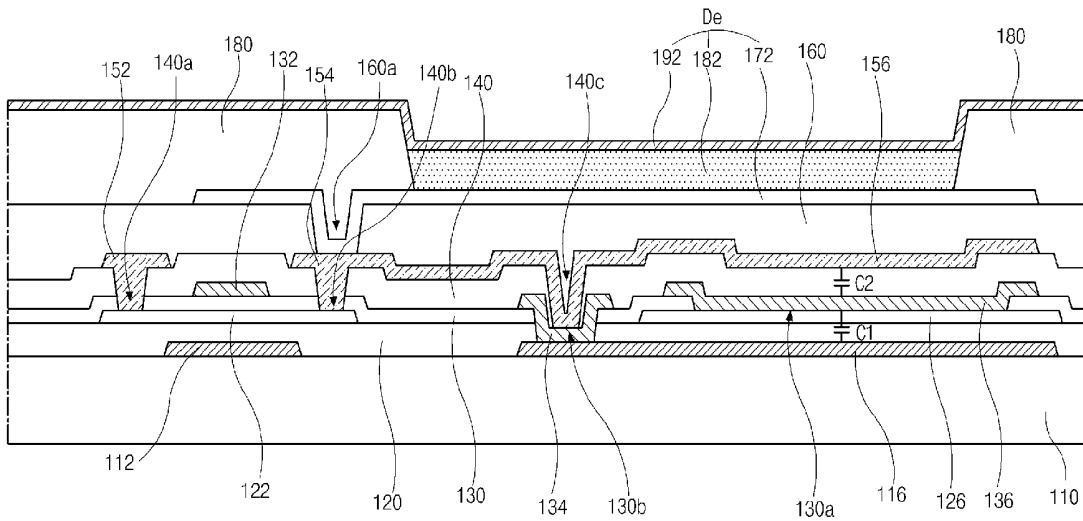

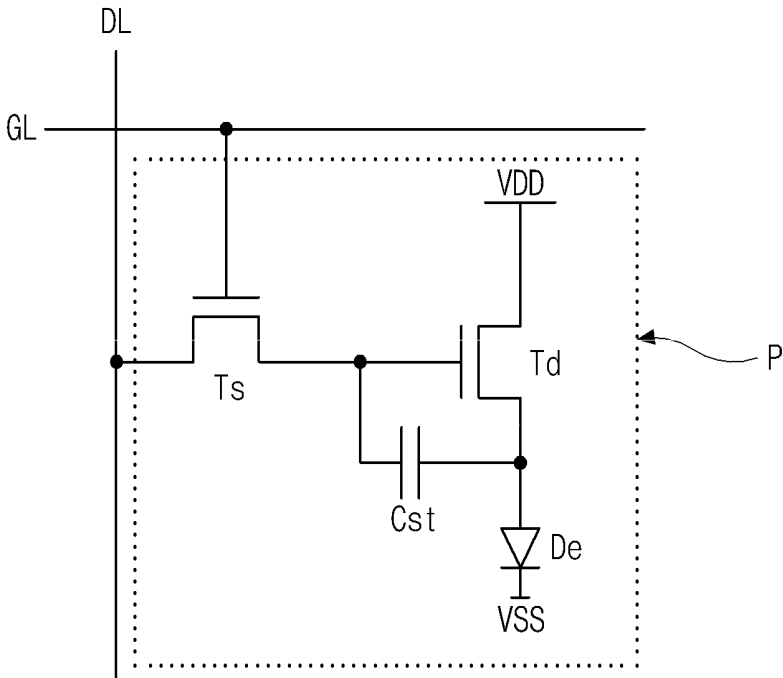

FIG. 1

Related Art

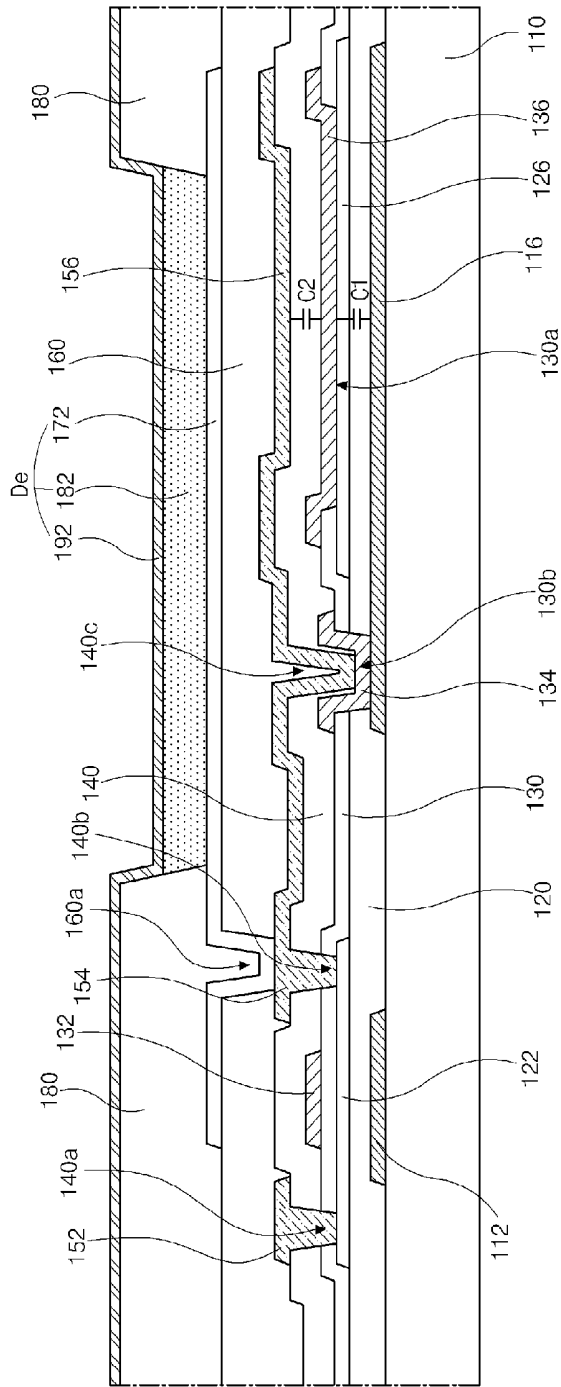

FIG. 2

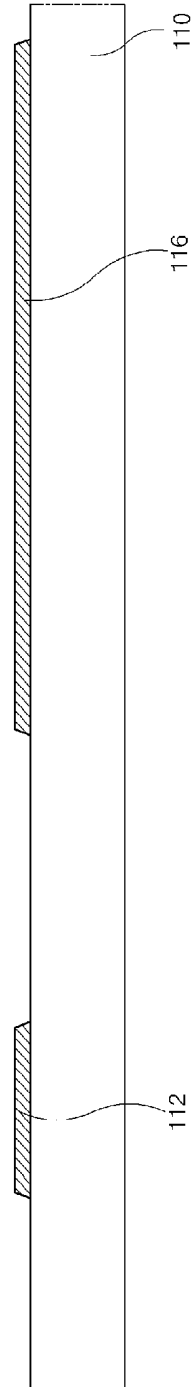

FIG. 3A

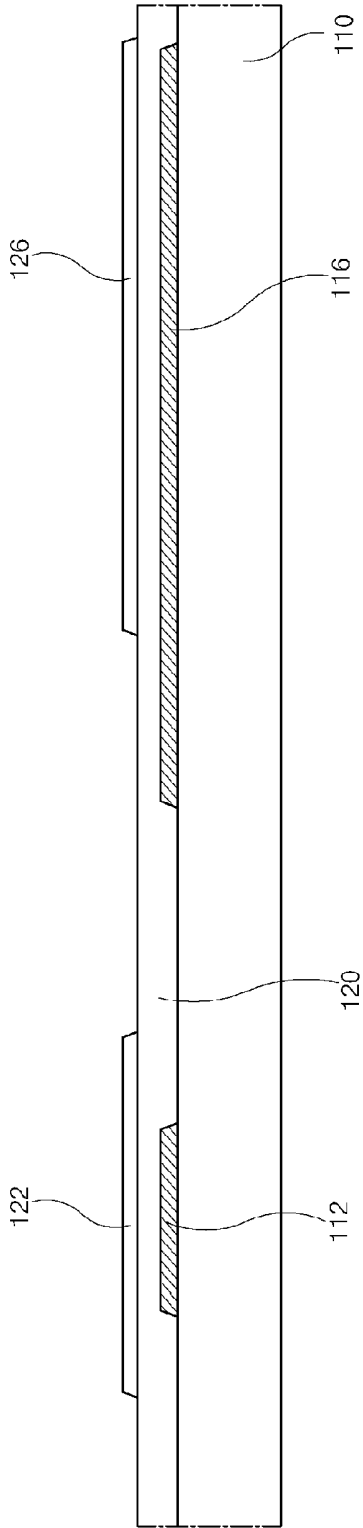

FIG. 3B

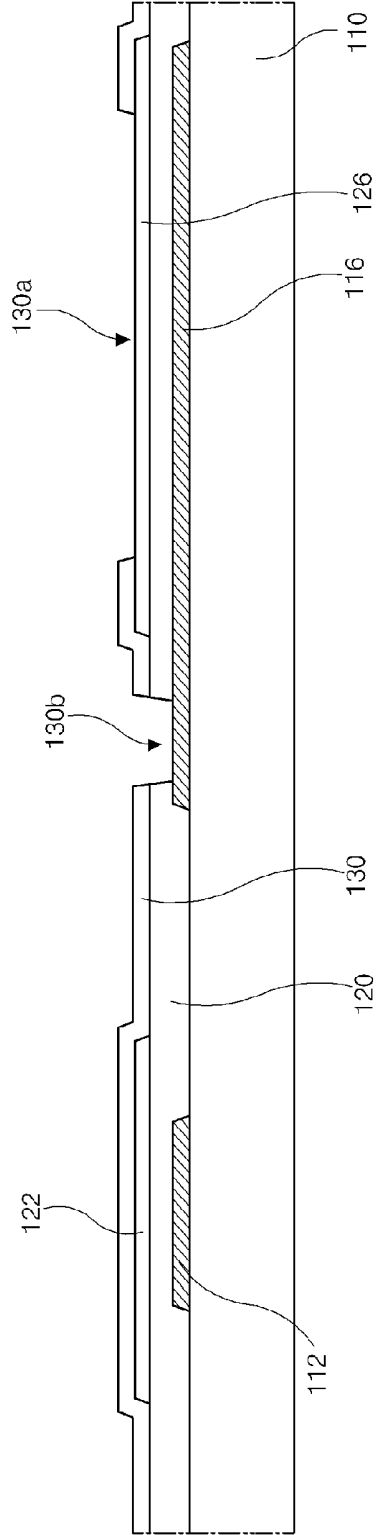

FIG. 3C

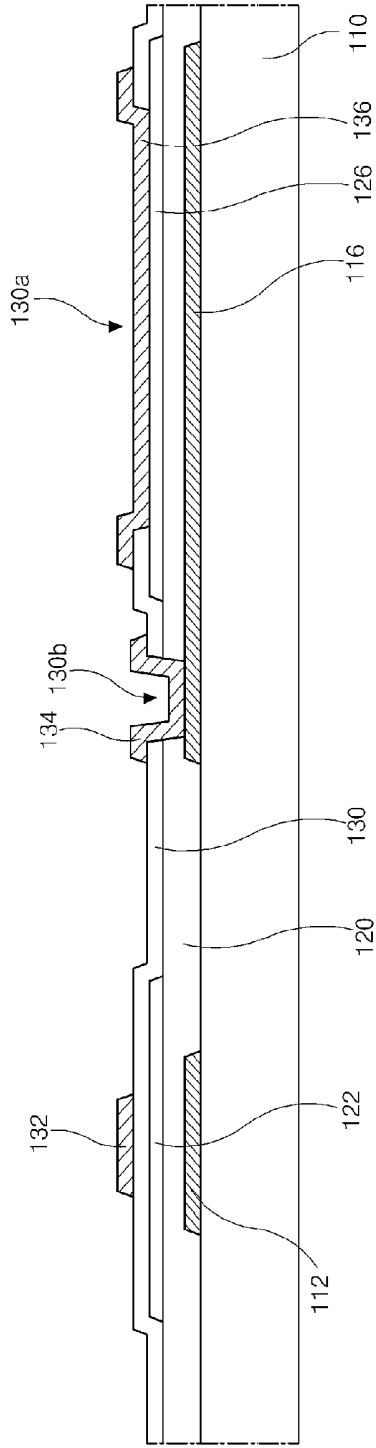

FIG. 3D

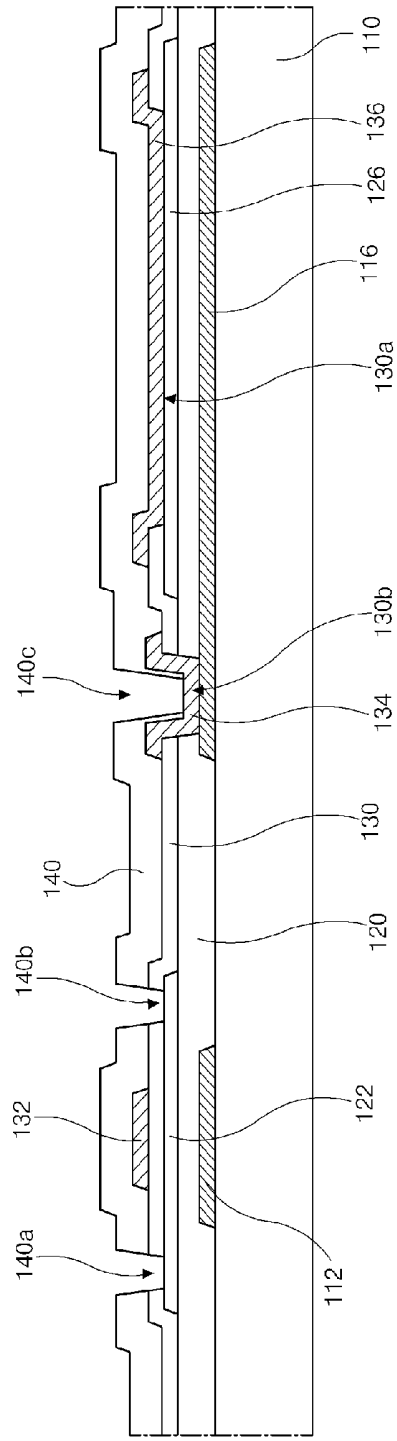

FIG. 3E

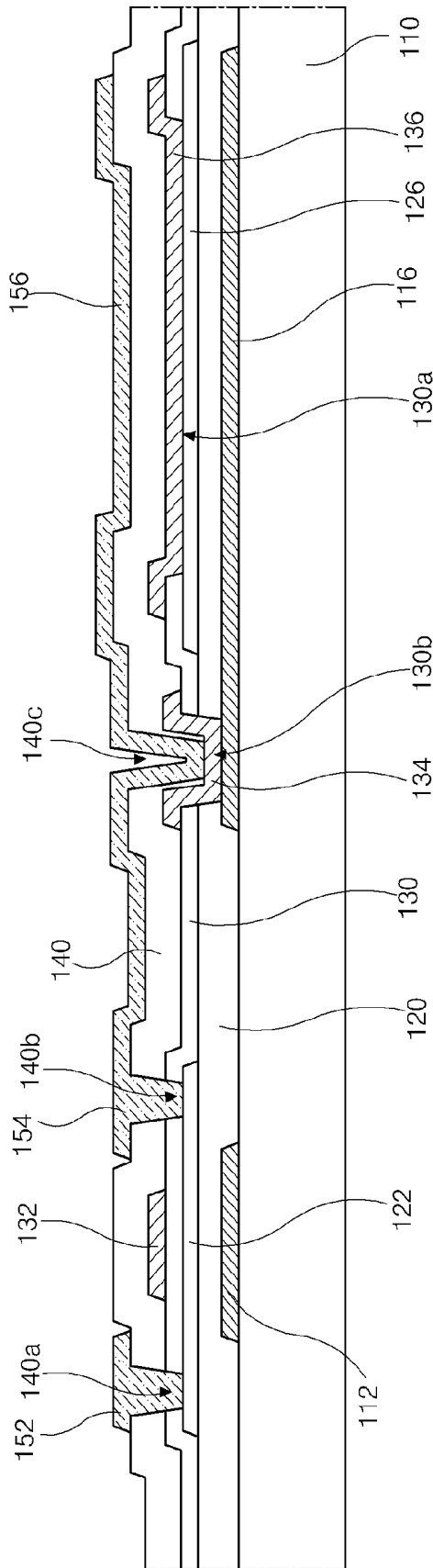

FIG. 3F

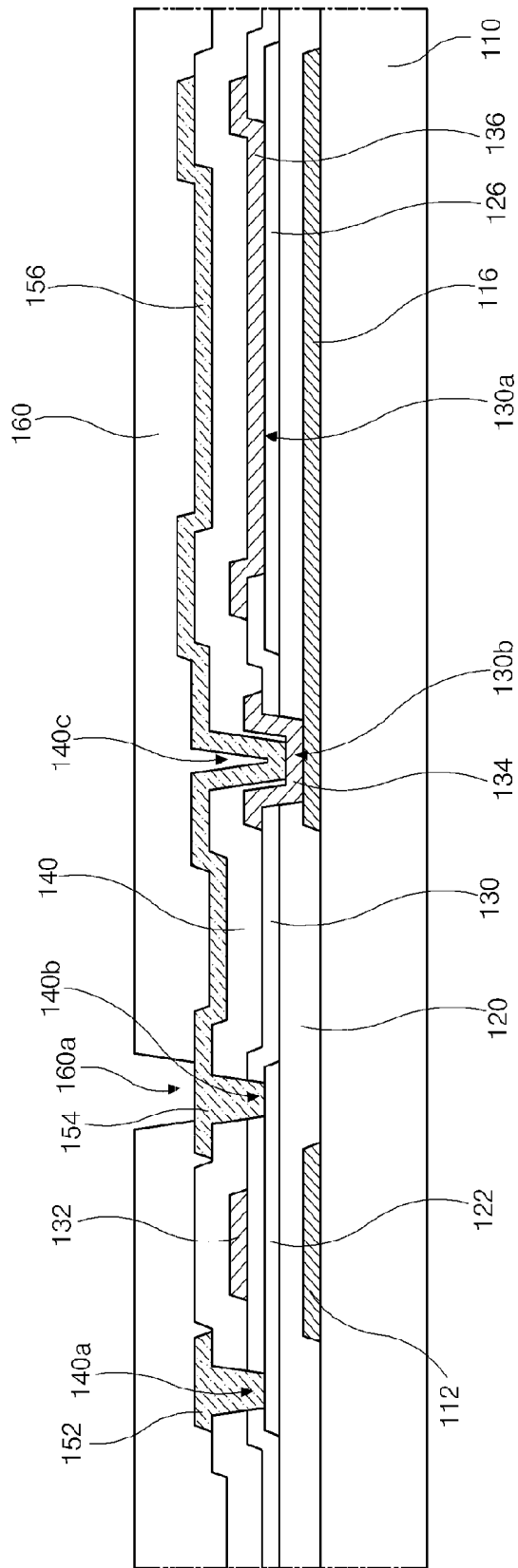

FIG. 3G

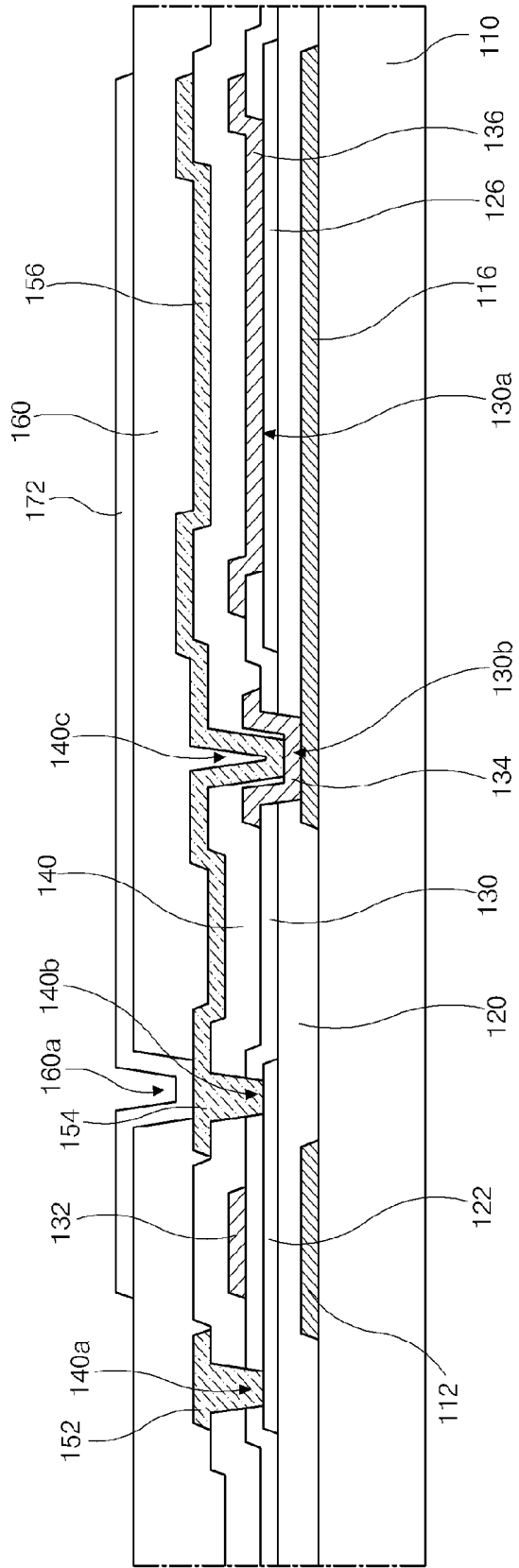

FIG. 3H

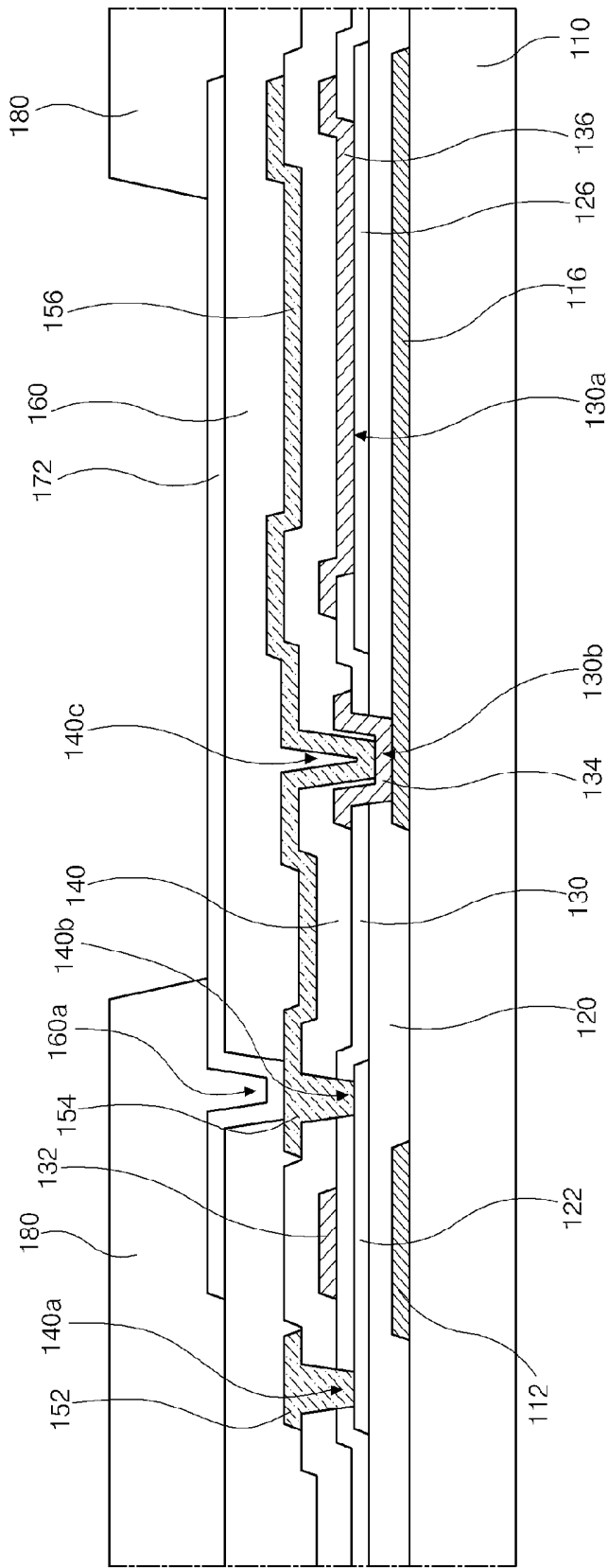

FIG. 3I

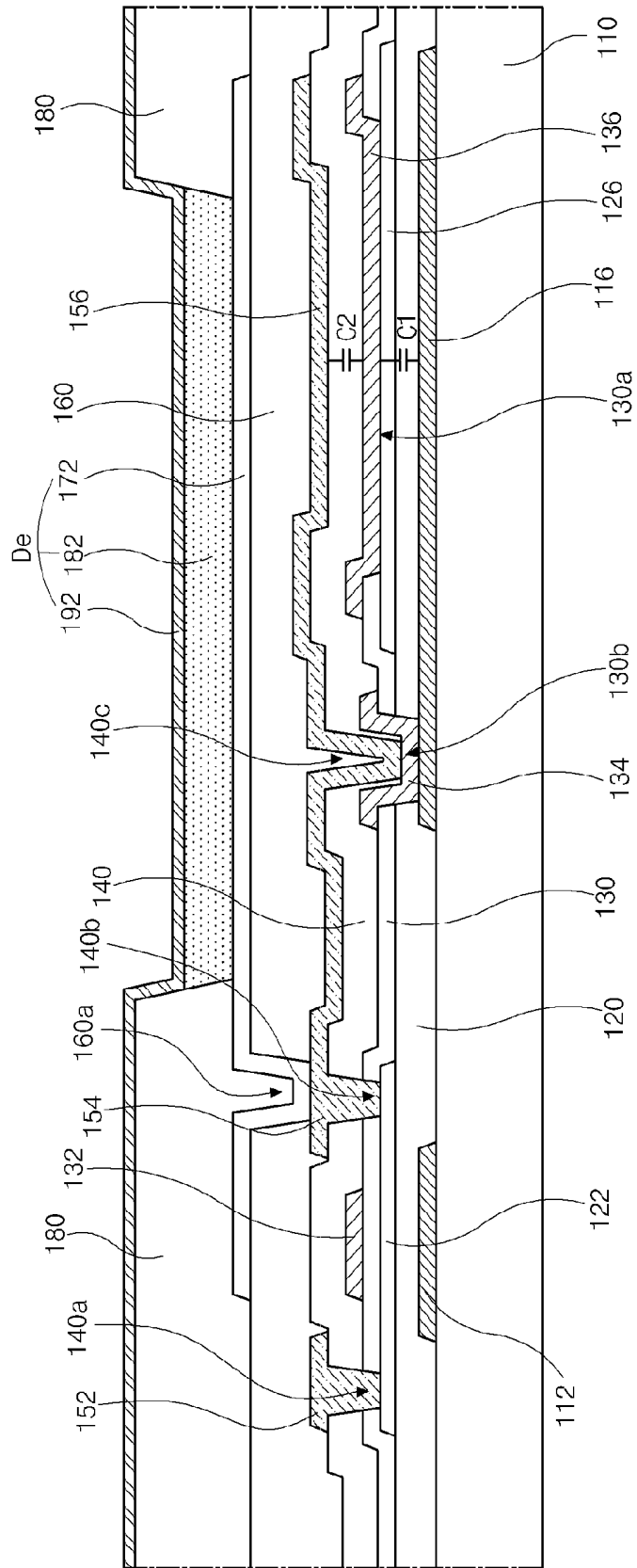

FIG. 3J

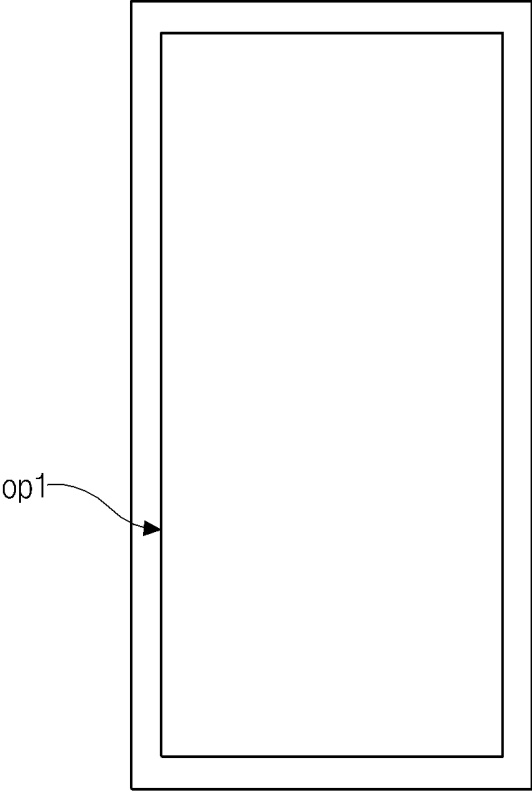

FIG. 4A

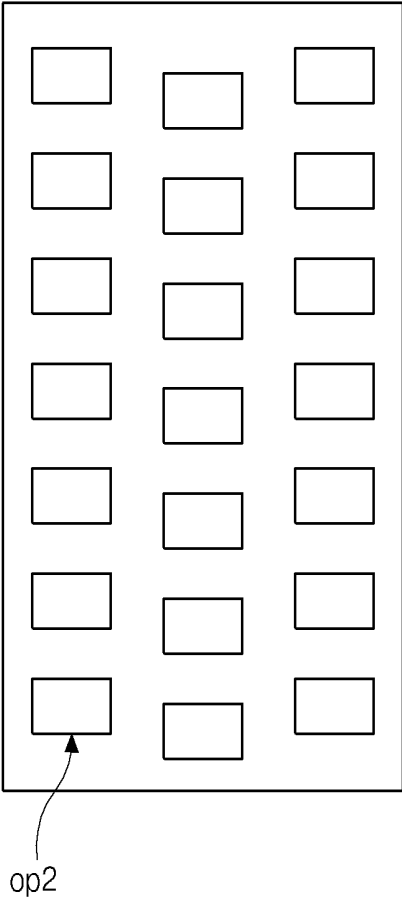
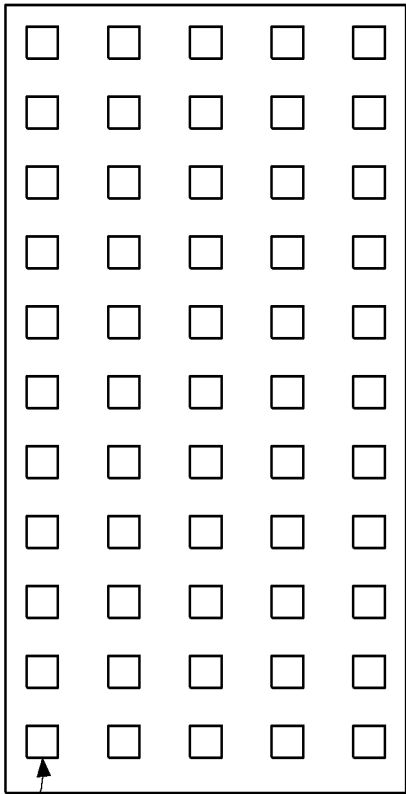

FIG. 4B



op3

FIG. 4C

**ORGANIC LIGHT EMITTING DIODE
DISPLAY DEVICE AND METHOD OF
FABRICATING THE SAME**

CROSS-REFERENCE TO RELATED
APPLICATION

[0001] The present application claims the priority benefit of Korean Patent Application No. 10-2013-0161519 filed in the Republic of Korea on Dec. 23, 2013, which is hereby incorporated by reference in their entirety.

BACKGROUND

[0002] 1. Field of the Disclosure

[0003] The present disclosure relates to an organic light emitting diode display device, and more particularly, to an organic light emitting diode display device that increases capacitance of a storage capacitor and a method of fabricating the same.

[0004] 2. Discussion of the Related Art

[0005] Recently, flat panel displays have been widely developed and applied to various fields because of their thin profile, light weight, and low power consumption.

[0006] Among the flat panel displays, organic light emitting diode (OLED) display devices, which may be referred to as organic electroluminescent display devices, emit light during loss of electron-hole pairs formed by injecting charges into a light emitting layer between a cathode for injecting electrons and an anode for injecting holes.

[0007] The OLED display devices include a flexible substrate such as plastic; because they are self-luminous, the OLED display devices have excellent contrast ratios; the OLED display devices have a response time of several micro seconds, and there are advantages in displaying moving images; the OLED display devices have wide viewing angles and are stable under low temperatures; since the OLED display devices are driven by a low voltage of direct current (DC) 5V to 15V, it is easy to design and manufacture driving circuits; and the manufacturing processes of the OLED display device are simple since only deposition and encapsulation steps are required.

[0008] The OLED display devices are classified into a passive matrix type and an active matrix type according to driving methods. Active matrix type display devices have been widely used because of their low power consumption, high definition and large-sized possibility.

[0009] FIG. 1 is a circuit diagram of one pixel region of an OLED display device according to the related art.

[0010] As shown in FIG. 1, an OLED display device includes a gate line GL, a data line DL, a switching thin film transistor Ts, a driving thin film transistor Td, a storage capacitor Cst and a light emitting diode De. The gate line GL and the data line DL cross each other to define a pixel region P. The switching thin film transistor Ts, the driving thin film transistor Td, the storage capacitor Cst and the light emitting diode De are formed in the pixel region P.

[0011] More particularly, a gate electrode of the switching thin film transistor Ts is connected to the gate line GL and a source electrode of the switching thin film transistor Ts is connected to the data line DL. A gate electrode of the driving thin film transistor Td is connected to a drain electrode of the switching thin film transistor Ts, and a source electrode of the driving thin film transistor Td is connected to a high voltage supply VDD. An anode of the light emitting diode De is

connected to a drain electrode of the driving thin film transistor Td, and a cathode of the light emitting diode De is connected to a low voltage supply VSS. The storage capacitor Cst is connected to the gate electrode and the drain electrode of the driving thin film transistor Td.

[0012] In operation of the OLED display device, when the switching thin film transistor Ts is turned on by a gate signal applied through the gate line GL, a data signal from the data line DL is applied to the gate electrode of the driving thin film transistor Td and an electrode of the storage capacitor Cst through the switching thin film transistor Ts. When the driving thin film transistor Td is turned on by the data signal, an electric current flowing through the light emitting diode De is controlled, thereby displaying an image. The light emitting diode De emits light due to the current supplied through the driving thin film transistor Td from the high voltage supply VDD.

[0013] Namely, the amount of the current flowing through the light emitting diode De is proportional to the magnitude of the data signal, and the intensity of light emitted by the light emitting diode De is proportional to the amount of the current flowing through the light emitting diode De. Thus, the pixel regions P show different gray levels depending on the magnitude of the data signal, and as a result, the OLED display device displays an image.

[0014] The storage capacitor Cst maintains charges corresponding to the data signal for a frame when the switching thin film transistor Ts is turned off. Accordingly, even if the switching thin film transistor Ts is turned off, the storage capacitor Cst allows the amount of the current flowing through the light emitting diode De to be constant and the gray level shown by the light emitting diode De to be maintained until a next frame.

[0015] To do this, capacitance of the storage capacitor Cst needs to be over a predetermined value. However, to implement high definition display devices, the size of the pixel region P decreases, and an area for the storage capacitor Cst also decreases. Therefore, the capacitance of the storage capacitor Cst is lowered. If the area for the storage capacitor Cst is increased, an effective emission area and an area for a compensation circuit are restricted. Accordingly, it is difficult to obtain sufficient capacitance of the storage capacitor Cst.

SUMMARY

[0016] Accordingly, the present disclosure is directed to an organic light emitting diode display device and a method of fabricating the same that substantially obviate one or more of the problems due to limitations and disadvantages of the related art.

[0017] An object of the present disclosure is to provide an organic light emitting diode display device and a method of fabricating the same that increase capacitance of a storage capacitor and improve the aperture ratio and brightness.

[0018] Another object of the present disclosure is to provide organic light emitting diode display device and a method of fabricating the same that increase design margins.

[0019] Additional features and advantages of these embodiments will be set forth in the description which follows, and in part will be apparent from the description, or may be learned by practice of the embodiments. The objectives and other advantages will be realized and attained by the structure particularly pointed out in the written description and claims hereof as well as the appended drawings.

[0020] To achieve these and other advantages and in accordance with the purpose of the present disclosure, as embodied and broadly described herein, according to one or more embodiments, an organic light emitting diode display device includes a driving thin film transistor including a first semiconductor layer, a gate insulating layer formed on the first semiconductor layer, a gate electrode formed on the gate insulating layer, a source electrode, and a drain electrode, the source electrode and the gate electrode formed co-planar with the gate electrode on a same side with respect to the gate insulating layer. The device further comprises a storage capacitor including a first capacitor electrode electrically coupled to the drain electrode of the driving thin film transistor, a buffer layer formed on the first capacitor electrode, a second semiconductor layer formed on the buffer layer, and a second capacitor electrode formed on the second semiconductor layer and electrically coupled to the gate electrode of the driving thin film transistor. The device additionally includes an organic light emitting diode (OLED) connected to the drain electrode of the driving thin film transistor and configured to emit light by current driven through the OLED by the driving thin film transistor. In one or more embodiments, the gate insulating layer has at least one hole in a region where the gate insulating layer overlaps the second semiconductor layer, thereby exposing the second semiconductor layer to the second capacitor electrode.

[0021] In another aspect, a method of fabricating an organic light emitting diode display device includes forming a driving thin film transistor including a first semiconductor layer, a gate insulating layer formed on the first semiconductor layer, a gate electrode formed on the gate insulating layer, a source electrode, and a drain electrode, the source electrode and the gate electrode formed co-planar with the gate electrode on a same side with respect to the gate insulating layer; forming a storage capacitor including a first capacitor electrode electrically coupled to the drain electrode of the driving thin film transistor, a buffer layer formed on the first capacitor electrode, a second semiconductor layer formed on the buffer layer, and a second capacitor electrode formed on the second semiconductor layer and electrically coupled to the gate electrode of the driving thin film transistor; and forming an organic light emitting diode (OLED) connected to the drain electrode of the driving thin film transistor and configured to emit light by current driven through the OLED by the driving thin film transistor. In one or more embodiments, the buffer layer, the second semiconductor layer and the gate insulating layer are formed subsequent to forming of the first capacitor electrode and prior to forming of the second capacitor electrode. In one or more embodiments, forming the gate insulating layer includes forming at least one hole in the gate insulating layer in a region where the gate insulating layer overlaps the second semiconductor layer by patterning the gate insulating layer to expose the second semiconductor layer through the gate insulating layer to the second capacitor electrode.

[0022] In another aspect, a method of fabricating an organic light emitting diode display device includes forming a first capacitor electrode over a substrate; forming a buffer layer over the first capacitor electrode; forming a first semiconductor layer and a second semiconductor layer over the buffer layer; and forming a gate insulating layer over the first semiconductor layer and the second semiconductor layer. The method also comprises forming at least one hole in the gate insulating layer in a region where the gate insulating layer

overlaps the second semiconductor layer by patterning the gate insulating layer, the hole exposing the second semiconductor layer through the gate insulating layer. The method further comprises forming a gate electrode on the gate insulating layer and forming a second capacitor electrode on the second semiconductor layer in the hole of the gate insulating layer, the second capacitor electrode being electrically coupled to the gate electrode. The method additionally comprises forming an inter insulating layer over the gate electrode and the second capacitor electrode; forming source and drain electrodes over the inter insulating layer, the drain electrode being electrically coupled to the first capacitor electrode; forming a passivation layer over the source and drain electrodes; and sequentially forming a first OLED electrode, an organic light emitting layer and a second OLED electrode over the passivation layer.

[0023] In one or more embodiments, an organic light emitting display (OLED) device comprises a thin film transistor that includes a first semiconductor layer on a buffer layer, a gate insulating layer on the first semiconductor layer, a gate electrode, a source electrode, and a drain electrode. The device further comprises a first capacitor electrically coupled between the gate electrode and either the drain electrode or the source electrode of the thin film transistor, the first capacitor formed in a second region of the substrate, the first capacitor including a first capacitor electrode, the buffer layer on the first capacitor electrode, a second semiconductor layer on the buffer layer, and a second capacitor electrode on the second semiconductor layer. In one or more embodiments, the second semiconductor layer is thinner than the gate insulating layer.

[0024] In one or more embodiments, an organic light emitting display (OLED) device comprises a thin film transistor formed in a first region of a substrate; an OLED formed in a second region of the substrate; a first capacitor coupled between a gate electrode and a drain electrode of the thin film transistor, the first capacitor formed at least partially in the second region of the substrate; and a second capacitor adjacent to the first capacitor and formed at least partially in the second region of the substrate, the second capacitor coupled between the gate and the drain electrodes of the thin film transistor and connected in parallel with the first capacitor.

[0025] It is to be understood that both the foregoing general description and the following detailed description are exemplary and explanatory and are intended to provide further explanation of the embodiments as claimed.

BRIEF DESCRIPTION OF THE DRAWINGS

[0026] The accompanying drawings, which are included to provide a further understanding of the invention and are incorporated in and constitute a part of this specification, illustrate embodiments of the invention and together with the description serve to explain the principles of the invention. In the drawings:

[0027] FIG. 1 is a circuit diagram of one pixel region of an OLED display device according to the related art;

[0028] FIG. 2 is a cross-sectional view of an OLED display device according to an embodiment of the present disclosure;

[0029] FIGS. 3A to 3J are cross-sectional views of an OLED display device in steps of fabricating the display device according to an embodiment of the present disclosure; and

[0030] FIGS. 4A to 4C are views of schematically illustrating holes of a storage capacitor according to an embodiment of the present disclosure.

DETAILED DESCRIPTION OF THE PREFERRED EMBODIMENTS

[0031] Reference will now be made in detail to the preferred embodiment, examples of which are illustrated in the accompanying drawings.

[0032] FIG. 2 is a cross-sectional view of an OLED display device according to an embodiment of the present invention. FIG. 2 shows one pixel region.

[0033] In FIG. 2, a light-blocking layer 112 and a first capacitor electrode 116 of a conductive material such as metal are formed on an insulating substrate 110.

[0034] A buffer layer 120 of an insulating material is formed on the light-blocking layer 112 and the first capacitor electrode 116 substantially all over the substrate 110.

[0035] A first oxide semiconductor layer 122 and a second oxide semiconductor layer 126 of an oxide semiconductor material are formed on the buffer layer 120. The first oxide semiconductor layer 122 is disposed over the light-blocking layer 112, and the second oxide semiconductor layer 126 is disposed over the first capacitor electrode 116. The first oxide semiconductor layer 122 has a wider width than the light-blocking layer 112, and a central portion of the first oxide semiconductor layer 122 overlaps the light-blocking layer 112. The second oxide semiconductor layer 126 overlaps the first capacitor electrode 116. At this time, the second oxide semiconductor layer 126 has a smaller area than the first capacitor electrode 116, and a portion of the first capacitor electrode 116 does not overlap the second oxide semiconductor layer 126.

[0036] A gate insulating layer 130 of an insulating material is formed on the first oxide semiconductor layer 122 and the second oxide semiconductor layer 126 substantially all over the substrate 110. The gate insulating layer 130 has a hole 130a exposing the second oxide semiconductor layer 126 and a capacitor contact hole 130b exposing the first capacitor electrode 116. The capacitor contact hole 130b is also formed in the buffer layer 120 under the gate insulating layer 130. Meanwhile, although not shown in the figure, the gate insulating layer 130 and the buffer layer 120 have a gate contact hole exposing the light-blocking layer 112.

[0037] A gate electrode 132, a connection pattern 134 and a second capacitor electrode 136 of a conductive material such as metal are formed on the gate insulating layer 130. In addition, a gate line (not shown) is formed on the gate insulating layer 130. The gate line extends in a first direction.

[0038] The gate electrode 132 overlaps the light-blocking layer 112 and has a narrower width than the light-blocking layer 112. Although not shown in the figure, the gate electrode 132 contacts the light-blocking layer 112 through the gate contact hole. Additionally, the connection pattern 134 contacts the first capacitor electrode 116 through the capacitor contact hole 130b. The second capacitor electrode 136 is spaced apart from the connection pattern 134, and the second capacitor electrode 136 overlaps the first capacitor electrode 116 and contacts the second oxide semiconductor layer 126 through the hole 130a. Although not shown in the figure, the second capacitor electrode 136 is connected to the gate electrode 132.

[0039] An inter insulating layer 140 of an insulating material is formed on the gate electrode 132, the connection pat-

tern 134 and the second capacitor electrode 136 substantially all over the substrate 110. The inter insulating layer 140 includes first and second contact holes 140a and 140b exposing top surfaces of both sides of the first oxide semiconductor layer 122. The first and second contact holes 140a and 140b are spaced apart from the gate electrode 132, and the first and second contact holes 140a and 140b are also formed in the gate insulating layer 130. In addition, the inter insulating layer 140 has a third contact hole 140c exposing the connection pattern 134.

[0040] A source electrode 152, a drain electrode 154 and a third capacitor electrode 156 of a conductive material such as metal are formed on the inter insulating layer 140. In addition, a data line (not shown) a power supply line (not shown) are formed on the inter insulating layer 140. The data line and the power supply line extend in a second direction. The data line crosses the gate line to define a pixel region.

[0041] The source and drain electrodes 152 and 154 are spaced apart from each other with respect to the gate electrode 132. The source and drain electrodes 152 and 154 contact both sides of the first oxide semiconductor layer 122 through the first and second contact holes 140a and 140b, respectively. The source and drain electrodes 152 and 154 are spaced apart from the gate electrode 132 and overlap the light-blocking layer 112. The drain electrode 154 is connected to the third capacitor electrode 156 and contacts the connection pattern 134 through the third contact hole 140c. In the meantime, the third capacitor electrode 156 overlaps the second capacitor electrode 136.

[0042] Here, the drain electrode 154 may directly contact the first capacitor electrode 116. Namely, the capacitor contact hole 130a and the connection pattern 134 may be omitted, and the third contact hole 140c may be formed in the inter insulating layer 140, the gate insulating layer 130 and the buffer layer 120 to expose the first capacitor electrode 116. The drain electrode 154 may contact the first capacitor electrode 116 through the third contact hole 140c.

[0043] Meanwhile, the first capacitor electrode 116 and the second capacitor electrode 136 form a first capacitor C1 with the buffer layer 120 and the second oxide semiconductor layer 126 interposed therebetween as a dielectric. The second capacitor electrode 136 and the third capacitor electrode 156 form a second capacitor C2 with the inter insulating layer 140 interposed therebetween as a dielectric. The first capacitor C1 and the second capacitor C2 are connected to each other in parallel to constitute a storage capacitor. In other words, in one or more embodiments, the first capacitor electrode 116 and the third capacitor electrode 156 are both connected to either a source 152 or a drain electrode 154 of the thin film transistor through a common connection pattern 134 through the third contact hole 140c. Both the gate insulating layer 130 and the inter insulating layer 140 absent in a vicinity of the connection pattern 134.

[0044] A passivation layer 160 of an insulating material is formed on the source and drain electrodes 152 and 154 and the third capacitor electrode 156 substantially all over the substrate 110. The passivation layer 160 has a flat top surface and has a drain contact hole 160a exposing the drain electrode 154. In the figure, although the drain contact hole 160a is formed directly over the second contact hole 140b, the drain contact hole 160a may be spaced apart from the second contact hole 140b.

[0045] A first electrode 172 of a conductive material having relatively high work function is formed on the passivation

layer 160. The first electrode 172 is disposed in each pixel region and contacts the drain electrode 154 through the drain contact hole 160a. Here, the first electrode 172 may be formed of a transparent conductive material.

[0046] A bank layer 180 of an insulating material is formed on the first electrode 172. The bank layer 180 covers edges of the first electrode 172 and exposes a central portion of the first electrode 172.

[0047] An organic light emitting layer 182 of an organic material is formed on the first electrode 172 exposed by the bank layer 180. The organic light emitting layer 182 may have a multi-layered structure of a hole transporting layer, a light-emitting material layer, and an electron transporting layer sequentially layered on the first electrode 172. The organic light emitting layer 182 may further include a hole injecting layer under the hole transporting layer and an electron injecting layer on the electron transporting layer.

[0048] A second electrode 192 of a conductive material having relatively low work function is formed on the organic light emitting layer 182 substantially all over the substrate 110. The second electrode 192 may be formed of an opaque metallic material.

[0049] The first electrode 172, the organic light emitting layer 182 and the second electrode 192 constitute an organic light emitting diode De. The first electrode 172 functions as an anode, and the second electrode 192 serves as a cathode. Here, the OLED display device may be a bottom emission type in which light from the organic light emitting layer 182 is outputted to the outside through the first electrode 172.

[0050] In the meantime, the gate electrode 132, the first oxide semiconductor layer 122, the source electrode 152 and the drain electrode 154 constitute a thin film transistor. The thin film transistor may have a top gate-type coplanar structure in which the first oxide semiconductor layer 122 as an active layer is disposed at the bottom, the gate electrode 132 is disposed at the top, and the gate electrode 132 and the source and drain electrodes 152 and 154 are disposed at a side of the oxide semiconductor layer 122.

[0051] In the present embodiments, since the light-blocking layer 112 is formed under the first oxide semiconductor layer 122, light from the outside or light from the organic light emitting layer 182 is prevented from reaching the first oxide semiconductor layer 122. The first oxide semiconductor layer 122 is prevented from being degraded by light, and a lifetime of the thin film transistor is prevented from being shortened. Moreover, the light-blocking layer 112 is electrically connected to the gate electrode 132 at the top and is used as an additional gate electrode. Thus, the thin film transistor of the present invention has a double gate structure and has further improvement in current characteristics.

[0052] The thin film transistor of FIG. 2 corresponds to a driving thin film transistor of an OLED display device. Although not shown in the figure, a switching thin film transistor, which has the same structure as the driving thin film transistor, is formed over the substrate 110.

[0053] In addition, a sensing thin film transistor having the same structure as the driving thin film transistor may be further formed.

[0054] Here, a gate electrode of the switching thin film transistor is connected to the gate line, and a source electrode of the switching thin film transistor is connected to the data line. The gate electrode 132 of the driving thin film transistor is connected to a drain electrode of the switching thin film

transistor, and the source electrode 152 of the driving thin film transistor is connected to the power supply line.

[0055] As stated above, the drain electrode 154 of the driving thin film transistor is connected to the first electrode 172 of the organic light emitting diode De, and the drain electrode 154 of the driving thin film transistor is also connected to the first capacitor electrode 116 and the third capacitor electrode 156 of the storage capacitor. The gate electrode 132 of the driving thin film transistor is connected to the second capacitor electrode 136 of the storage capacitor.

[0056] The positions and names of the source electrode 152 and the drain electrode 154 of the driving thin film transistor are determined according to carriers, and the positions and names of the source electrode 152 and the drain electrode 154 may be changed to each other.

[0057] In the meantime, as mentioned above, the storage capacitor of the present invention includes the first and second capacitors C1 and C2 connected in parallel and has larger capacitance than a capacitor having the same area as the storage capacitor of the present invention. At this time, to decrease a distance between the first capacitor electrode 116 and the second capacitor electrode 136, the gate insulating layer 130 between the first capacitor electrode 116 and the second capacitor electrode 136 is removed, and the buffer layer 120 is prevented from being etched by using the second oxide semiconductor layer 126 as an etching-prevention layer. Since the second oxide semiconductor layer 126 has a thinner thickness than the gate insulating layer 130, the distance between the first and second capacitor electrodes 116 and 136 decreases, and the capacitance of the first capacitor C1 further increases.

[0058] Accordingly, the area for the storage capacitor can be decreased by an increase in the capacitance. The effective emission area where light from the organic light emitting layer 182 is emitted increases in the bottom emission type OLED display device, and brightness of the display device increases.

[0059] The structure of the storage capacitor of the present invention may be applied to a top emission type OLED display device in addition to the bottom emission type OLED display device. That is, the OLED display device may be a top emission type where the first electrode 172 is formed of an opaque conductive material or includes a transparent conductive layer and a reflective layer under the transparent conductive layer, the second electrode 182 transmits light, and light from the organic light emitting layer 182 is outputted to the outside through the second electrode 192. At this time, since the area for the storage capacitor decreases by an increase in the capacitance of the first capacitor C1, other thin film transistors and capacitors for compensation can be added, and design margins increase.

[0060] Hereinafter, a method of fabricating an OLED display device according to an embodiment of the present disclosure with reference to accompanying drawings.

[0061] FIGS. 3A to 3J are cross-sectional views of an OLED display device in steps of fabricating the display device according to an embodiment of the present disclosure.

[0062] In FIG. 3A, a first conductive material layer (not shown) is formed on an insulating substrate 110 by depositing a conductive material such as metal by a sputtering method, for example, and the first conductive material layer is selectively removed through a photolithographic process using a mask, thereby forming a light-blocking layer 112 and a first capacitor electrode 116.

[0063] Here, the insulating substrate **110** may be a glass substrate or a plastic substrate. The light-blocking layer **112** and the first capacitor electrode **116** may be formed of at least one of aluminum (Al), copper (Cu), molybdenum (Mo), chromium (Cr), nickel (Ni), tungsten (W), and an alloy thereof.

[0064] In FIG. 3B, a buffer layer **120** is formed on the light-blocking layer **112** and the first capacitor electrode **116** by depositing an insulating material substantially all over the substrate **110**. The buffer layer **120** may be formed of an inorganic insulating material such as silicon oxide (SiO₂).

[0065] Next, an oxide semiconductor layer (not shown) is formed on the buffer layer **120** by depositing an oxide semiconductor material, and the oxide semiconductor layer is selectively removed through a photolithographic process using a mask, thereby forming a first oxide semiconductor layer **122** over the light-blocking layer **112** and a second oxide semiconductor layer **126** over the first capacitor electrode **116**. Here, the first oxide semiconductor layer **122** has a wider width than the light-blocking layer **112**, and a central portion of the first oxide semiconductor layer **122** overlaps the light-blocking layer **112**. Meanwhile, the second oxide semiconductor layer **126** overlaps the first capacitor electrode **116**. At this time, the second oxide semiconductor layer **126** has a smaller area than the first capacitor electrode **116**, and a portion of the first capacitor electrode **116** does not overlap the second oxide semiconductor layer **126**.

[0066] In one or more embodiments, the second semiconductor layer **126** and the first semiconductor layer **122** are formed in a same process with a same thickness. The first and second oxide semiconductor layers **122** and **126** may be formed of indium gallium zinc oxide (IGZO), indium tin zinc oxide (ITZO), indium zinc oxide (IZO), zinc oxide (ZnO), indium gallium oxide (IGO), or indium aluminum zinc oxide (IAZO).

[0067] In FIG. 3C, a gate insulating layer **130** is formed on the first and second oxide semiconductor layers **122** and **126** by depositing an insulating material substantially all over the substrate **110** by a chemical vapor deposition method, for example. The gate insulating layer **130** may be formed of an inorganic insulating material such as silicon oxide (SiO₂).

[0068] Next, the gate insulating layer **130** and the buffer layer **120** thereunder are selectively removed through a photolithographic process using a mask, thereby forming a hole **130a** exposing the second oxide semiconductor layer **126**, a capacitor contact hole **130b** exposing the first capacitor electrode **116**, and a gate contact hole (not shown) exposing the light-blocking layer **112**. Here, the hole **130a** is formed only in the gate insulating layer **130**, and the capacitor contact hole **130b** and the gate contact hole are formed in the gate insulating layer **130** and the buffer layer **120**. In other words, forming the gate insulating layer includes forming at least one hole (e.g., **130a**) in the gate insulating layer **130** in a region where the gate insulating layer **130** overlaps the second semiconductor layer **126**, by patterning the gate insulating layer **130**.

[0069] In FIG. 3D, a second conductive material layer (not shown) is formed on the gate insulating layer **130** by depositing a conductive material such as metal by a sputtering method, for example, and the second conductive material layer is selectively removed through a photolithographic process using a mask, thereby forming a gate electrode **132**, a connection pattern **134**, a second capacitor electrode **136**, and a gate line (not shown).

[0070] The gate electrode **132** has a narrower width than the light-blocking layer **112** and overlaps the light-blocking layer

112. The gate electrode **132** contacts the light-blocking layer **112** through the gate contact hole (not shown). The connection pattern **134** contacts the first capacitor electrode **116** through the capacitor contact hole **130b**. The second capacitor electrode **136** is spaced apart from the connection pattern **134**, and the second capacitor electrode **136** overlaps the first capacitor electrode **116** and contacts the second oxide semiconductor layer **126** through the hole **130a**. In other words, the second semiconductor layer **126** is exposed through the gate insulating layer **130** (at hole **130a**) to the second capacitor electrode **136**. In such embodiments, the second semiconductor layer **126** is formed thinner than the gate insulating layer **130**. Although not shown in the figure, the second capacitor electrode **136** is connected to the gate electrode **132**, and the gate line extends in a first direction.

[0071] The gate electrode **132**, the connection pattern **134**, the second capacitor electrode **136**, and the gate line may be formed of at least one of aluminum (Al), copper (Cu), molybdenum (Mo), chromium (Cr), nickel (Ni), tungsten (W), and an alloy thereof.

[0072] In FIG. 3E, an inter insulating layer **140** is formed on the gate electrode **132**, the connection pattern **134**, the second capacitor electrode **136**, and the gate line by depositing or applying an insulating material substantially all over the substrate **110**, and the inter insulating layer **140** is selectively removed through a photolithographic process using a mask, thereby forming first and second contact holes **140a** and **140b** and a third contact hole **140c**. The first and second contact holes **140a** and **140b** expose top surfaces of both sides of the first oxide semiconductor layer **122**, respectively, and the third contact hole **140c** exposes the connection pattern **134**. Although the third contact hole **140c** is disposed directly over the capacitor contact hole **130b**, the third contact hole **140c** may be spaced apart from the capacitor contact hole **130b**.

[0073] The inter insulating layer **140** may be formed of an inorganic insulating material such as silicon oxide (SiO₂) and silicon nitride (SiN_x) or an organic insulating material such as benzocyclobutene and photo acryl.

[0074] Next, in FIG. 3F, a third conductive material layer (not shown) is formed on the inter insulating layer **140** by depositing a conductive material such as metal by a sputtering method, for example, and the third conductive material layer is selectively removed through a photolithographic process using a mask, thereby forming source and drain electrodes **152** and **154**, a third capacitor electrode **156**, a data line (not shown), and a power supply line (not shown).

[0075] The source and drain electrodes **152** and **154** are spaced apart from each other with respect to the gate electrode **132**. The source and drain electrodes **152** and **154** contact both sides of the first oxide semiconductor layer **122** through the first and second contact holes **140a** and **140b**, respectively. In addition, the source and drain electrodes **152** and **154** are spaced apart from the gate electrode **132** and overlap the light-blocking layer **112**. The drain electrode **154** is connected to the third capacitor electrode **156** and contacts the connection pattern **134** through the third contact hole **140c**. In the meantime, the third capacitor electrode **156** overlaps the second capacitor electrode **136**. The data line and the power supply line extend in a second direction. The data line crosses the gate line to define a pixel region.

[0076] As stated above, the drain electrode **154** may directly contact the first capacitor electrode **116**. Namely, the capacitor contact hole **130a** and the connection pattern **134** may be omitted, and the third contact hole **140c** may be

formed in the inter insulating layer 140, the gate insulating layer 130 and the buffer layer 120 to expose the first capacitor electrode 116. The drain electrode 154 may contact the first capacitor electrode 116 through the third contact hole 140c.

[0077] The source and drain electrodes 152 and 154, the third capacitor electrode 156, the data line and the power supply line may be formed of at least one of aluminum (Al), copper (Cu), molybdenum (Mo), chromium (Cr), nickel (Ni), tungsten (W), and an alloy thereof.

[0078] In FIG. 3G, a passivation layer 160 is formed on the source and drain electrodes 152 and 154, the third capacitor electrode 156, the data line and the power supply line by depositing or applying an insulating material substantially all over the substrate 110, and the passivation layer 160 is selectively removed through a photolithographic process using a mask, thereby forming a drain contact hole 160a exposing the drain electrode 154. The drain contact hole 160a is formed directly over the second contact hole 140b. Alternatively, the drain contact hole 160a may be spaced apart from the second contact hole 140b.

[0079] The passivation layer 160 may be formed of an inorganic insulating material such as silicon oxide (SiO₂) and silicon nitride (SiN_x) or an organic insulating material such as benzocyclobutene and photo acryl. Beneficially, the passivation layer 160 may be formed of an organic insulating material to flatten a top surface thereof.

[0080] Next, in FIG. 3H, a first electrode material layer (not shown) is formed on the passivation layer 160 by depositing a conductive material having relatively high work function by a sputtering method, for example, and the first electrode material layer is selectively removed through a photolithographic process using a mask, thereby forming a first electrode 172. The first electrode 172 is disposed in each pixel region and is connected to the drain electrode 154 through the drain contact hole 160a.

[0081] The first electrode 172 may be formed of a transparent conductive material such as indium tin oxide and indium zinc oxide.

[0082] In FIG. 3I, a bank material layer (not shown) is formed on the first electrode 172 by depositing or applying an insulating material, and the bank material layer is selectively removed through a photolithographic process using a mask, thereby forming a bank layer 180. The bank layer 180 covers edges of the first electrode 172 and exposes a central portion of the first electrode 172.

[0083] Meanwhile, although not shown in the figure, a spacer may be further formed on the bank layer 180.

[0084] In FIG. 3J, an organic light emitting layer 182 is formed on the first electrode 172 exposed by the bank layer 180 by selectively depositing an organic material over the substrate 110 including the bank layer 180 by an evaporation method, for example. The organic light emitting layer 182 may have a multi-layered structure of a hole transporting layer, a light-emitting material layer, and an electron transporting layer sequentially layered on the first electrode 172. The organic light emitting layer 182 may further include a hole injecting layer under the hole transporting layer and an electron injecting layer on the electron transporting layer.

[0085] Next, a second electrode 192 is formed on the organic light emitting layer 182 by depositing a conductive material having relatively low work function substantially all over the substrate 110 by a sputtering method, for example.

[0086] The second electrode 192 may be formed of an opaque metallic material such as aluminum and chromium.

[0087] The first electrode 172, the organic light emitting layer 182 and the second electrode 192 constitute an organic light emitting diode De. The first electrode 172 functions as an anode, and the second electrode 192 serves as a cathode. Here, the OLED display device may be a bottom emission type in which light from the organic light emitting layer 182 is outputted to the outside through the first electrode 172. Alternatively, the OLED display device may be a top emission type where a reflective layer is further formed under the first electrode 172 and a thickness of the second electrode 182 is adjusted to transmit light.

[0088] In the present invention, a storage capacitor is formed by first and second capacitors C1 and C2, which are constituted by the first, second and third capacitor electrodes 116, 136 and 156 and are connected to each other in parallel. Here, when the gate contact hole (not shown) and the storage contact hole 130b are formed, the gate insulating layer 130 between the first capacitor electrode 116 and the second capacitor electrode 136 is removed using the second oxide semiconductor layer 126 as an etching prevention layer. Thus, without an increase in a process, since a thickness of the second oxide semiconductor layer 126 is thinner than the gate insulating layer 130, a distance between the first and second capacitor electrodes 116 and 136 decreases, and the capacitance of the first capacitor C1 increases. Therefore, an area for the storage capacitor can be decreased by the increase in the capacitance. Accordingly, in the bottom emission type OLED display device, the effective emission area, and brightness of the display device increases. In the top emission type OLED display device, other thin film transistors and capacitors for compensation can be added, and design margins increase.

[0089] In the embodiment of the present invention, the thin film transistor includes oxide semiconductor as an active layer. Alternatively, the thin film transistor may include low temperature polycrystalline silicon (LTPS) as an active layer. In this case, a step of doping impurities may be further performed, and the gate insulating layer 130 and the buffer layer 120 may be formed of an inorganic insulating material such as silicon nitride (SiN_x) in addition to silicon oxide (SiO₂).

[0090] Meanwhile, in the embodiment of the present disclosure, the storage capacitor has one hole 130a exposing the second oxide semiconductor layer 126. Alternatively, the number and size of holes and a distance between adjacent holes may be varied. In other words, in one or more embodiments, the gate insulating layer 130 has a plurality of spatially separated holes in the region where the storage capacitor is formed, between the second capacitor electrode 136 and the second semiconductor layer 126 to expose the second semiconductor layer 126 to the second capacitor electrode 136. Furthermore, the gate insulating layer 130 extends partially into a region between the second capacitor electrode 136 and the second semiconductor layer 126 to cover a part of the second semiconductor layer 126.

[0091] FIGS. 4A to 4C are views of schematically illustrating holes of a storage capacitor according to an embodiment of the present invention. FIGS. 4A to 4C show the number and size of holes and the distance between adjacent holes with respect to an area of the storage capacitor.

[0092] In FIG. 4A, the storage capacitor may include a hole op1, and the hole op1 may have a size corresponding to electrodes of the storage capacitor. For example, the size of the hole op1 may be 34 micrometers by 84 micrometers.

[0093] In FIG. 4B, the storage capacitor may include a plurality of holes op2. For example, the number of holes op2

may be 21, the size of each hole op2 may be 8 micrometers by 6 micrometers, and the holes op2 may be disposed with a distance of about 6 micrometers therebetween.

[0094] In FIG. 4C, the storage capacitor may include a plurality of holes op3. For example, the number of holes op3 may be 55, the size of each hole op3 may be 3 micrometers by 3 micrometers, and the holes op3 may be disposed with a distance of about 5 micrometers therebetween.

[0095] For instance, in a reference case that the storage capacitor does not include a hole, the capacitance of the storage capacitor is 512.6 fF. In FIG. 4A where the storage capacitor includes the hole op1, the capacitance is 723.8 fF and increases by about 141.2% as compared with the reference case. In FIG. 4B where the storage capacitor includes the holes op2, the capacitance is 695 fF and increases by about 135.58% as compared with the reference case. In FIG. 4C where the storage capacitor includes the holes op3, the capacitance is 733.8 fF and increases by about 143.15% as compared with the reference case.

[0096] Here, the holes op3 of FIG. 4C have a smaller total area than the hole op1 of FIG. 4A, and the capacitance in FIG. 4C is larger than the capacitance in FIG. 4A because of a fringe field effect at edges of the holes op3.

[0097] Accordingly, the storage capacitor with the hole op1 or holes op2 or op3 can have the capacitance increased by about 35% to about 43% in comparison to the storage capacitor without a hole.

[0098] In the present invention, by forming the hole or holes having various sizes, numbers and distances therebetween, the capacitance of the storage capacitor can be increased.

[0099] It will be apparent to those skilled in the art that various modifications and variations can be made in a display device of the present disclosure without departing from the spirit or scope of the embodiments. Thus, it is intended that the present disclosure covers the modifications and variations of this invention provided they come within the scope of the appended claims and their equivalents.

What is claimed is:

1. An organic light emitting diode display device comprising:

a driving thin film transistor including a first semiconductor layer, a gate insulating layer formed on the first semiconductor layer, a gate electrode formed on the gate insulating layer, a source electrode, and a drain electrode, the source electrode and the drain electrode formed co-planar with the gate electrode on a same side with respect to the gate insulating layer;

a storage capacitor including a first capacitor electrode electrically coupled to the drain electrode of the driving thin film transistor, a buffer layer formed on the first capacitor electrode, a second semiconductor layer formed on the buffer layer, and a second capacitor electrode formed on the second semiconductor layer and electrically coupled to the gate electrode of the driving thin film transistor; and

an organic light emitting diode (OLED) connected to the drain electrode of the driving thin film transistor and configured to emit light by current driven through the OLED by the driving thin film transistor,

wherein the gate insulating layer has at least one hole in a region where the gate insulating layer overlaps the second semiconductor layer, thereby exposing the second semiconductor layer to the second capacitor electrode.

2. The organic light emitting diode display device of claim 1, wherein the second semiconductor layer is formed thinner than the gate insulating layer.

3. The organic light emitting diode display device of claim 1, wherein the storage capacitor further includes an insulating layer formed on the second capacitor electrode and a third capacitor electrode formed on the insulating layer and electrically coupled to the drain electrode.

4. The organic light emitting diode display device of claim 1, wherein the first semiconductor layer and the second semiconductor layer include an oxide semiconductor material.

5. The organic light emitting diode display device of claim 1, further comprising a light-blocking layer disposed under the first semiconductor layer and electrically connected to the gate electrode.

6. The organic light emitting diode display device of claim 1, further comprising a connection pattern between the drain electrode and the first capacitor electrode and disposed on a same layer as the second capacitor electrode, the gate insulating layer absent in a region surrounding the connection pattern.

7. A method of fabricating an organic light emitting diode display device, comprising:

forming a driving thin film transistor including a first semiconductor layer, a gate insulating layer formed on the first semiconductor layer, a gate electrode formed on the gate insulating layer, a source electrode, and a drain electrode, the source electrode and the drain electrode formed co-planar with the gate electrode on a same side with respect to the gate insulating layer;

forming a storage capacitor including a first capacitor electrode electrically coupled to the drain electrode of the driving thin film transistor, a buffer layer formed on the first capacitor electrode, a second semiconductor layer formed on the buffer layer, and a second capacitor electrode formed on the second semiconductor layer and electrically coupled to the gate electrode of the driving thin film transistor; and

forming an organic light emitting diode (OLED) connected to the drain electrode of the driving thin film transistor and configured to emit light by current driven through the OLED by the driving thin film transistor,

wherein the buffer layer, the second semiconductor layer and the gate insulating layer are formed subsequent to forming of the first capacitor electrode and prior to forming of the second capacitor electrode, and

wherein forming the gate insulating layer includes forming at least one hole in the gate insulating layer in a region where the gate insulating layer overlaps the second semiconductor layer by patterning the gate insulating layer to expose the second semiconductor layer through the gate insulating layer to the second capacitor electrode.

8. The method of claim 7, wherein the second semiconductor layer is formed thinner than the gate insulating layer.

9. The method of claim 7, wherein forming the storage capacitor further includes forming an insulating layer on the second capacitor electrode and forming a third capacitor electrode on the insulating layer to be electrically coupled to the drain electrode.

10. The method of claim 7, further comprising forming a light-blocking layer disposed under the first semiconductor layer and electrically connected to the gate electrode.

11. The method of claim 7, wherein forming the second capacitor electrode includes forming a connection pattern between the drain electrode and the first capacitor electrode.

12. A method of fabricating an organic light emitting diode display device, comprising:

- forming a first capacitor electrode over a substrate;
- forming a buffer layer over the first capacitor electrode;
- forming a first semiconductor layer and a second semiconductor layer over the buffer layer;
- forming a gate insulating layer over the first semiconductor layer and the second semiconductor layer;
- forming at least one hole in the gate insulating layer in a region where the gate insulating layer overlaps the second semiconductor layer by patterning the gate insulating layer, the hole exposing the second semiconductor layer through the gate insulating layer;
- forming a gate electrode on the gate insulating layer and forming a second capacitor electrode on the second semiconductor layer in the hole of the gate insulating layer, the second capacitor electrode being electrically coupled to the gate electrode;
- forming an inter insulating layer over the gate electrode and the second capacitor electrode;
- forming source and drain electrodes over the inter insulating layer, the drain electrode being electrically coupled to the first capacitor electrode;
- forming a passivation layer over the source and drain electrodes; and
- sequentially forming a first OLED electrode, an organic light emitting layer and a second OLED electrode over the passivation layer.

13. The method of claim 12, wherein forming the source and drain electrodes includes forming a third capacitor electrode electrically to the drain electrode and disposed over the inter insulating layer and the second capacitor electrode prior to forming of the passivation layer.

14. The method of claim 12, wherein forming the first capacitor electrode includes forming a light-blocking layer disposed under the first semiconductor layer and electrically connected to the gate electrode.

15. The method of claim 12, wherein forming the second capacitor electrode includes forming a connection pattern between the drain electrode and the first capacitor electrode.

16. An organic light emitting display (OLED) device comprising:

- a thin film transistor that includes a first semiconductor layer on a buffer layer, a gate insulating layer on the first semiconductor layer, a gate electrode, a source electrode, and a drain electrode; and
- a first capacitor electrically coupled between the gate electrode and either the drain electrode or the source electrode of the thin film transistor, the first capacitor formed in a second region of the substrate, the first capacitor including a first capacitor electrode, the buffer layer on the first capacitor electrode, a second semiconductor layer on the buffer layer, and a second capacitor electrode on the second semiconductor layer, wherein the second semiconductor layer is thinner than the gate insulating layer.

17. The OLED device of claim 16, wherein the second semiconductor layer and the first semiconductor layer are formed in a same process with a same thickness.

18. The OLED device of claim 16, wherein the gate insulating layer extends partially into the second region between the second capacitor electrode and the second semiconductor layer to cover a part of the second semiconductor layer.

19. The OLED device of claim 16, wherein the gate insulating layer has a plurality of spatially separated holes in the second region between the second capacitor electrode and the second semiconductor to expose the second semiconductor layer to the second capacitor electrode.

20. The OLED device of claim 16, further comprising a second capacitor adjacent to the first capacitor, the second capacitor including the second capacitor electrode, an inter insulating layer on the second capacitor electrode, and a third capacitor electrode on the inter insulating layer, the first capacitor and the second capacitor electrically coupled to each other in parallel.

21. The OLED device of claim 20, wherein the first capacitor electrode and the third capacitor electrode are both connected to either a source or a drain electrode of the thin film transistor through a common connection pattern, both the gate insulating layer and the inter insulating layer absent in a vicinity of the connection pattern.

22. The OLED device of claim 16, further comprising an OLED formed in an emission area of the substrate, the emission area overlapping at least partially with the second region of the substrate.

23. An organic light emitting display (OLED) device comprising:

- a thin film transistor formed in a first region of a substrate;
- an OLED formed in a second region of the substrate;
- a first capacitor coupled between a gate electrode and a drain electrode of the thin film transistor, the first capacitor formed at least partially in the second region of the substrate; and
- a second capacitor adjacent to the first capacitor and formed at least partially in the second region of the substrate, the second capacitor coupled between the gate and the drain electrodes of the thin film transistor and connected in parallel with the first capacitor.

24. The OLED device of claim 23, wherein:

- the first capacitor comprises a first capacitor electrode, a buffer layer, a semiconductor layer, and a second capacitor electrode formed contiguously;
- the second capacitor comprises the second capacitor electrode, an inter insulating layer, and a third capacitor electrode, formed contiguously; and
- the second capacitor electrode is a common electrode shared between the first and second capacitors.

25. The OLED device of claim 23, wherein:

- the second capacitor electrode is coupled to the gate of the thin film transistor; and
- the first and third capacitor electrodes are both commonly connected to the drain electrode of the thin film transistor through a common connection pattern, the buffer layer and the inter insulating layers absent in a vicinity of the common connection pattern.

* * * * *

专利名称(译)	有机发光二极管显示装置及其制造方法		
公开(公告)号	US20150179724A1	公开(公告)日	2015-06-25
申请号	US14/575321	申请日	2014-12-18
[标]申请(专利权)人(译)	乐金显示有限公司		
申请(专利权)人(译)	LG DISPLAY CO., LTD.		
当前申请(专利权)人(译)	LG DISPLAY CO., LTD.		
[标]发明人	LEE YOUNG JANG JEONG HO YOUNG		
发明人	LEE, YOUNG-JANG JEONG, HO-YOUNG		
IPC分类号	H01L27/32 H01L27/12 H01L51/56 H01L29/786		
CPC分类号	H01L27/3272 H01L27/3262 H01L27/3265 H01L2227/323 H01L29/7869 H01L27/1259 H01L51/56 H01L27/3258 H01L27/1225 H01L27/1255 H01L21/28008 H01L21/82 H01L27/32 H01L27/3241 H01L27/3244 H01L2021/775		
优先权	1020130161519 2013-12-23 KR		
其他公开文献	US9324740		
外部链接	Espacenet USPTO		

摘要(译)

一种有机发光二极管显示装置，包括：驱动薄膜晶体管，包括第一半导体层、栅极绝缘层，形成在第一半导体层上。该装置还包括存储电容器，包括电耦合到驱动薄膜晶体管的漏电极的第一电容器电极，形成在第一电容器电极上的缓冲层，形成在缓冲层上的第二半导体层，以及第二电容器电极形成在第二半导体层上并且电耦合到驱动薄膜晶体管的栅电极。该器件还包括连接到驱动晶体管的漏电极的有机发光二极管。栅极绝缘层在栅极绝缘层与第二半导体层重叠的区域中具有至少一个孔，从而将第二半导体层暴露于第二电容器电极。

